



60040

Product Description

Gypsum wall light fitting with G9 lampholder. Can be painted to match wall colour.

Complies with standard EN60598-1 and any other specific standards.



Dimensions

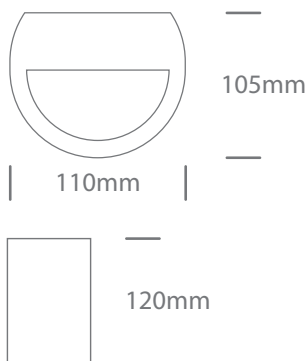

Order Code

60040

Lampholder

G9

Finish

White



Technical Data

Input Voltage: 100-240V
Input Frequency: 50/60Hz
Watts: 40W
Number of lamps: 1
IP rate: IP20

Construction: Gypsum
Diffuser:
Dimmable: Depending on lamp
Warranty: 2 years

